



Model FT10 Non-Metallic

AIR OPERATED DOUBLE DIAPHRAGM PUMPS

Specifications

Suction & Discharge Size:	1" x 1"
Standard Porting Location*:	End
Connection Type*:	ANSI/DIN/ISO flange
Air Inlet & Air Exhaust Size:	1/2" FNPT x 1/2" FNPT

*Optional NPT or BSP threaded center port location in either horizontal or vertical position

Capabilities

Maximum Flow Rate:	49 gpm (185 lpm)
Maximum Air Supply Pressure:	100 psi (6.9 bar)
Displacement Per Stroke:	0.084 gal (0.32 lit)
Minimum Air Inlet Pressure:	10 psig (0.7 bar)
Maximum Particle Size :	0.25 in (6.4 mm)
Sound Pressure:	73.6 dB(A)
Operating temperature:	Determined by elastomers



Performance

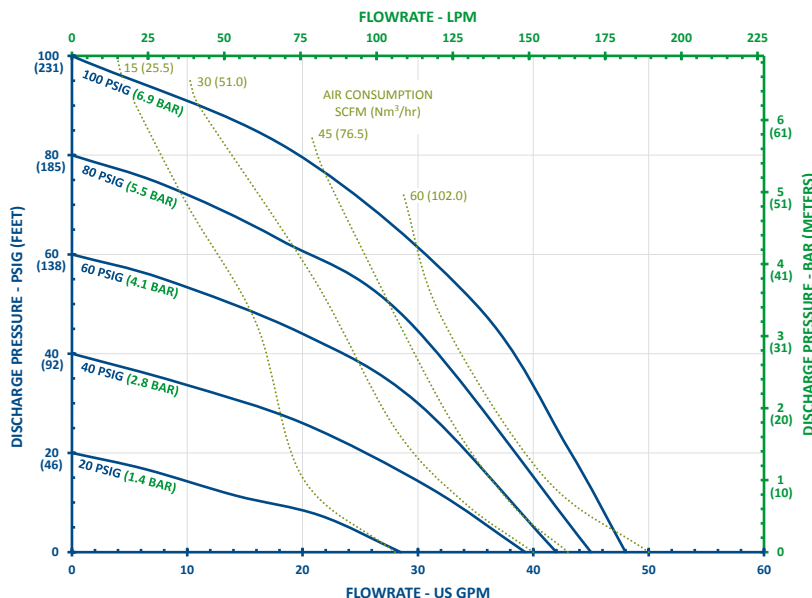

Note: Full stroke diaphragm allows performance to be equal for all elastomers.

Typical Applications

- Acids & Bases
- Plating Solutions
- Wastewater
- Paints, Inks, Solvents
- Ceramic Slip and Glaze
- Lubricants and Oils

Typical Industries

- Mining
- Paints and Coatings
- Ceramics
- Pulp and Paper
- Electroplating & Anodizing
- Wastewater
- Marine
- Chemical Manufacturing & Distribution
- OEM's

CHANGE IS IN THE AIR

Construction

Wetted Materials:	Polypropylene, PVDF
Diaphragm Materials:	Neoprene, Santoprene™, FKM, EPDM, PTFE, Buna, Hytrel®, Polyurethane
Air Valve:	GFRPP, Aluminum
Ball Materials:	Neoprene, Buna, EPDM, FKM, Santoprene™, PTFE, 316SS
Seat Materials:	Polypropylene, PVDF
O-ring Materials:	Buna, FKM, Santoprene™, Polyurethane, FEP/FKM

Santoprene™ is a registered trademark of Exxon Mobil Corp.
Hytrel® is a registered trademark of Dupont™

Pat. <http://ftiair.com/resources/ip/>

Dimensions

Maximum Height:	17-7/8 in (454 mm)
Maximum Width:	16-13/16 in (427 mm)
Maximum Depth:	10-11/16 in (271 mm)

Weight

Polypropylene:	24.0 lb (10.9 kg)
PVDF:	34.1 lb (15.5 kg)

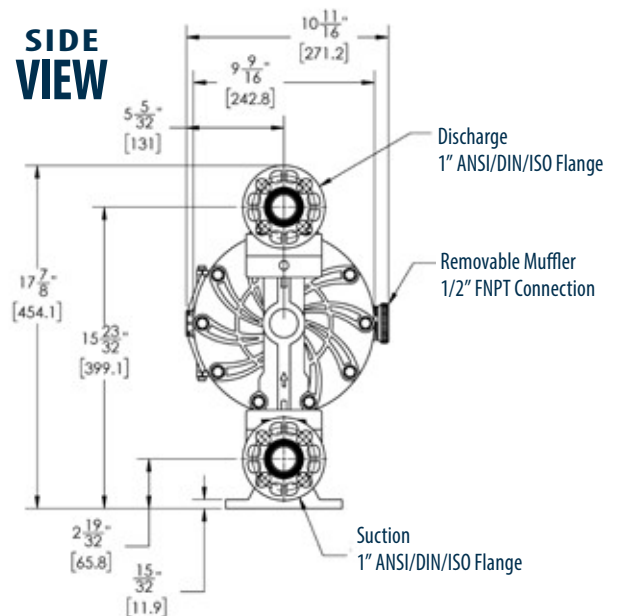
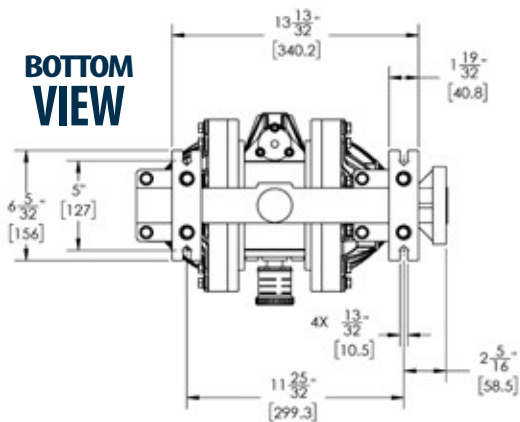
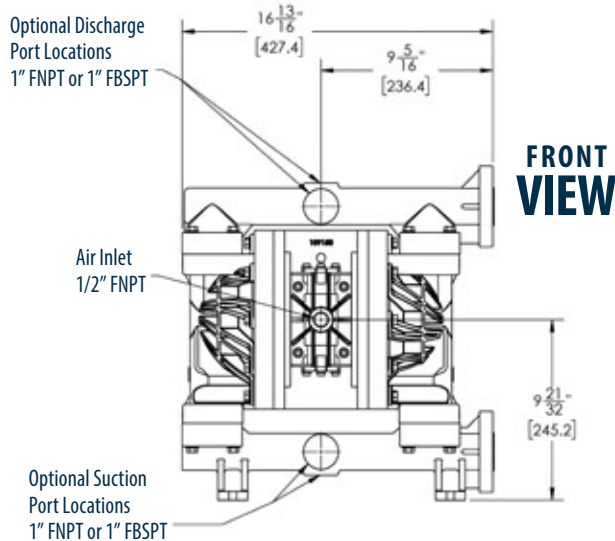

FTI AIR

921 GREENGARDEN ROAD ERIE, PA 16501
Tel: (800) 934-9384 • Fax: (814) 459-3460
www.FTIAIR.com

